

White LED Charge Pump With 8 Drivers

FEATURES

- Powers Up to 2 sets of 4 LEDs Each For Backlight Application.
- Up to 25mA/LED Drive for Backlight
- Single-Wire 8-Step Brightness Control
- Over temperature Over Voltage, Output Short Protection
- Soft Start with Low Input Ripple and EMI
- Maximized Efficiency
- 2.7V to 5.5V Supply Voltage Range
- 3mmx4mm 20-Pin QFN Package

DESCRIPTION

The BL144 is a low noise charge pump LED driver with regulated constant current sink for uniform intensity. It is designed to drive 2 sets of four LEDs (LED1-4, LED5-8) at up to 25mA per LED for backlighting application. The BL144 requires only four small ceramic capacitors and two current set resistors for a complete LED power supply and current controller.

Built-in soft-start circuitry prevents excessive inrush current during start-ups. The 1MHz fixed-frequency switching allows for tiny external components, and the regulation scheme is optimized to ensure low EMI and low input ripple. Two independent full-scale current settings are set by two external resistors on RB1 and RB2 pins.

Shutdown mode and current output levels are selected via two logic inputs ENB1 and ENB2 pins. ENB1 and ENB2 are toggled to adjust the LED currents via internal counters and DACs. The part

is shut down when both ENB1 and ENB2 are low for $>10\mu\text{s}$.

The charge pump optimizes efficiency based on the voltage across the LED current sources. The BL144 is available in a 3mm x 4mm 20-lead QFN package.

PIN ASSIGNMENT

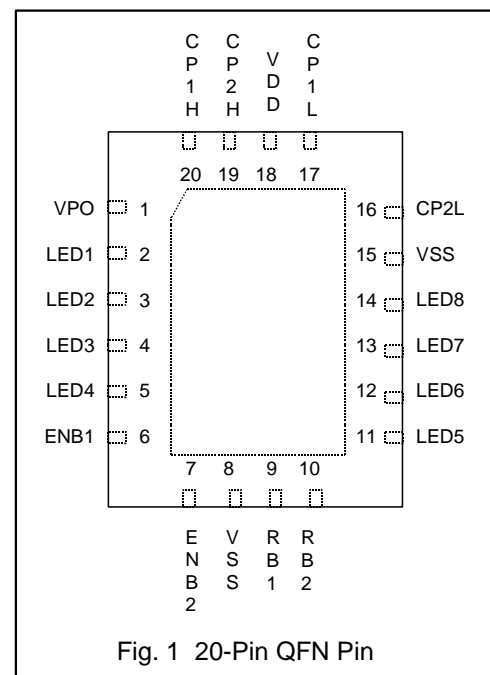

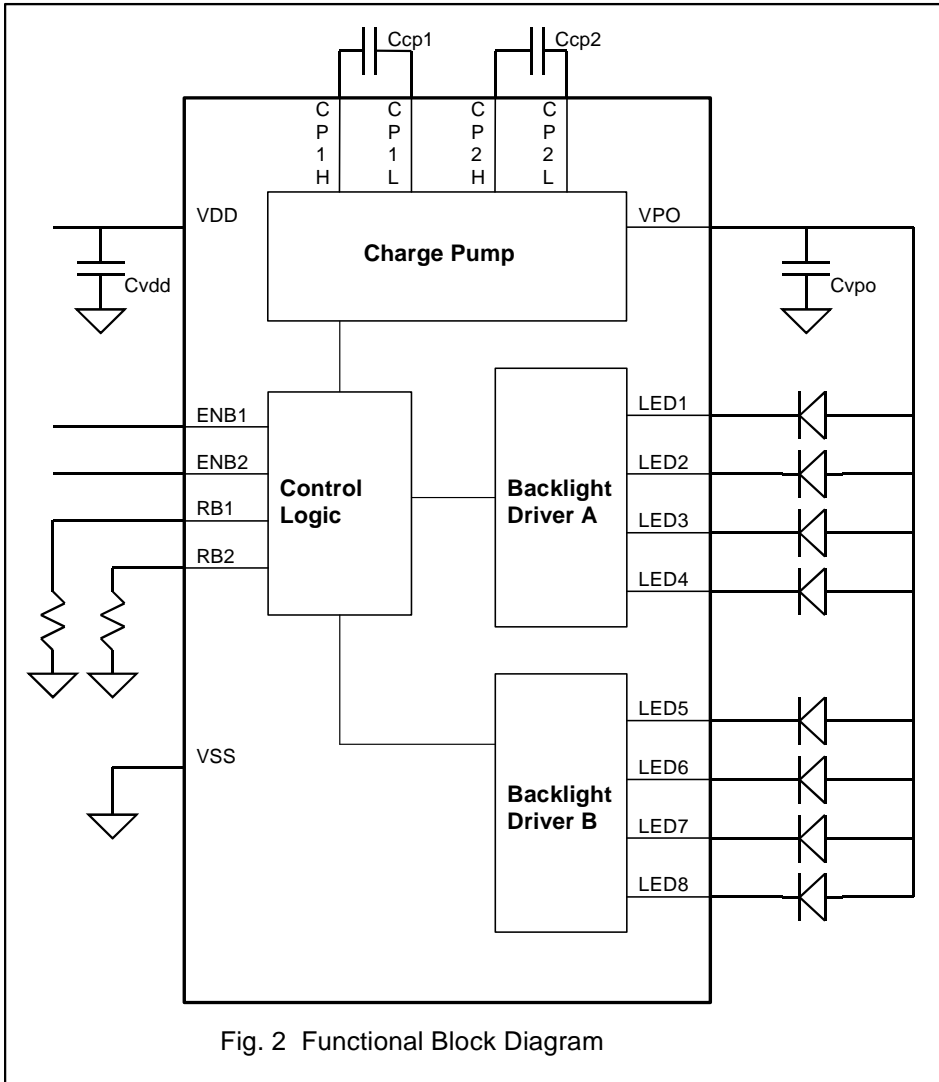

PIN DESCRIPTION

PIN	SYMBOL	DESCRIPTION
20, 17, 19, 16	CP1H, CP1L, CP2H, CP2L	Pump Capacitor Pins, A 1 to 2.2 μ F ceramic capacitor should be connected from CP1H to CP1L and CP2H to CP2L.
1	VPO	Pump Output, Used to Power All LEDs. This pin is enabled or disabled using the ENB1 and ENB2 inputs. A 1 to 2.2 μ F ceramic capacitor should be connected to ground
6, 7	ENB1, ENB2	Inputs. The ENB1 and ENB2 pins are used to program the LED output currents. The counter is decremented on the rising edge of the strobe signal. The counter data is transferred to the driver bias circuit after a 10 μ s delay. Holding the ENB1 or ENB2 pin low will set the LED current to 0. If both inputs are held low or leaved open for longer than 10 μ s the part will go into shutdown.
2,	LED1,	Outputs. LED1 to LED4 are the Backlight current source outputs. The LEDs

7, 4, 5	LED2, LED3, LED4	are connected between VPO (anodes) and LED1-4 (cathodes). The current to each LED output is programmed via the ENB1 inputs, and the full-scale setting resistor connected between RB1 and VSS.
11, 12, 13, 14	LED5, LED6, LED7, LED8	Outputs. LED5 to LED8 are the Backlight current source outputs. The LEDs are connected between VPO (anodes) and LED5-8 (cathodes). The current to each LED output is programmed via the ENB2 input, and the full-scale setting resistor is connected between RB2 to VSS.
9, 10	RB1, RB2	LED Full-Scale Current Resistor Pins. Resistors connected between each of these pins and VSS are used to set the full-scale current level for LED1-4 and LED5-8 drivers.
8, 15	VSS	Ground. This pin should be connected to a low impedance ground plane.
18	VDD	Supply voltage. This pin should be bypassed with a 2.2 μ F, or greater low ESR ceramic capacitor.
21	Exposed Pad	This pad should be connected directly to a low impedance ground plane for optimal thermal and electrical performance.

FUNCTIONAL DESCRIPTION

1) Power Management

The BL144 uses a switched capacitor charge pump to boost VPO output to as much as 2 times the input voltage up to 6V. A two phase non-overlapping clock activates the charge pump switches. The pump capacitors are charged on alternate clock phases from VDD to minimize input current ripple and VPO output voltage ripple. This sequence of charging and discharging the pump capacitors continues at a constant frequency of 1MHz .

2) LED Brightness/Dimming Control

The brightness of the LEDs may be controlled by varying the current flow through the LED. The LED1-4 currents are delivered by four programmable current sources. Eight current settings (0mA to 24mA, RB1 = 8.5k) are available by strobing the ENB1 pin. Each rising edge of the strobe signal decrements a 3-bit down counter which controls an exponential DAC. The output current then changes to the programmed value at about 10 μ s after the strobe signal has stopped. The counter will wrap around when strobing passes 0. The width of the strobe signals are limited to within 200nS for both High and

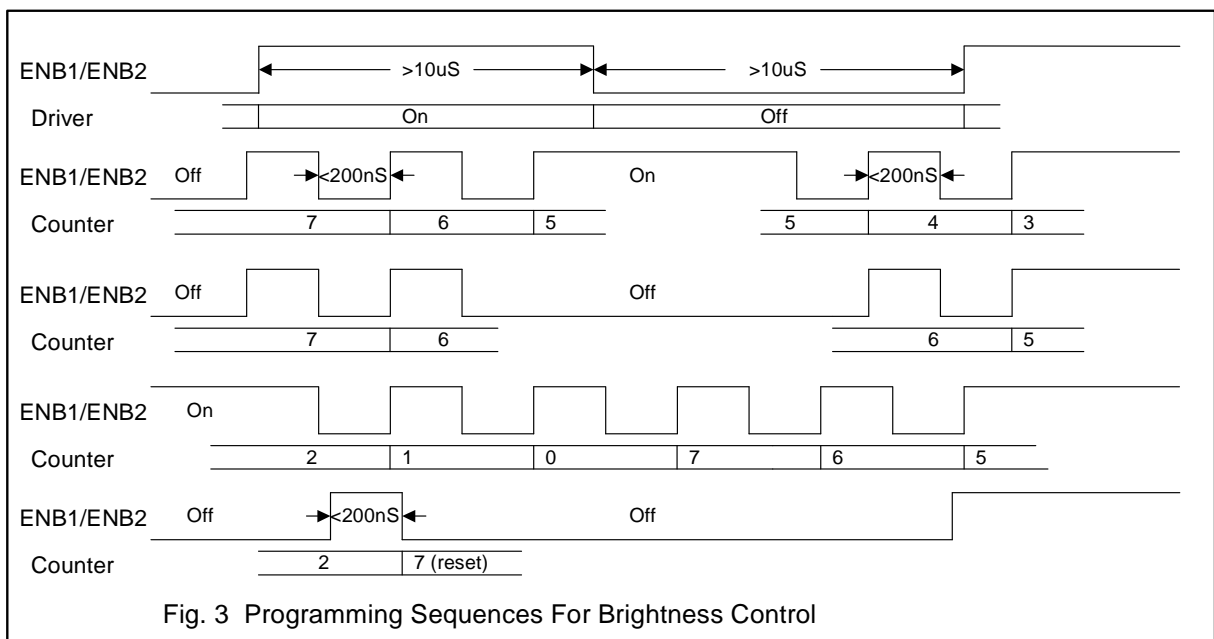

Fig. 3 Programming Sequences For Brightness Control

Low pulses.

The LED5-8 currents are delivered with the same approach, by four programmable current source. Eight current settings (0mA to 24mA, RB2 = 8.5k) are available by strobing the ENB2 pin. The programming requirements are as shown in Fig. 3. The full-scale output current is calculated as follows:

$$\text{LED1-4} = (0.5\text{V}/\text{RB1}) \cdot 350$$

$$\text{LED5-8} = (0.5\text{V}/\text{RB2}) \cdot 350$$

Table 1 below shows the normalized correspondent counter values.

Count	LED1-4, LED5-8
7	24mA
6	12mA
5	6mA
4	3mA
3	1.5mA
2	0.75mA
1	0.375mA
0	0mA

Table 1 Counter Values (normalized per Rb=8.5k)

3) Soft-Start

The BL144 employs a soft-start feature on its charge pump to prevent excessive inrush current and supply droop when the part is enabled. The current available to the VPO pin is increased gradually. This allows VDD to slowly charge the VPO output capacitor to prevent large charging currents.

4) Shutdown Current

In shutdown mode all the circuitry is turned off and the BL144 draws theoretically zero amount of current from the VDD supply. The BL144 enters shutdown mode when both the ENB1 and ENB2 pins are Low for >10µs. ENB1 and ENB2 inputs have 130k internal pull down resistors which will set the device in shutdown mode when these pins are in a high impedance state.

5) Thermal Protection

The BL144 has built-in over temperature protection. At internal junction temperatures of around 120°C a thermal shutdown will occur. This will disable all of the current sources and charge pumps as if it is in shutdown mode until the die has cooled by about 50°C. This thermal cycling will continue until the fault has been corrected.

6) Short Circuit Protection

When VPO pin experiences an output load of 10Ω or less and without any diode characteristics during start up, the device will consider this as a short circuit condition and limit the VPO output current to within 30mA. This will continue until the fault is removed or the device is put in shut down mode.

7) Unused LED Output

The unused driver pins should be left unconnected. The device will automatically detect the unused outputs during start up and have them disabled.

Electrical Characteristics

ABSOLUTE MAXIMUM RATINGS

PARAMETER	MAX	UNITS	NOTES
Supply Voltage	8	V	Vdd pin
Input Voltage	Vdd+0.5	V	All Inputs
Package Dissipation	2	W	20-QFN
Storage Temperature	-55 to 150	°C	
Junction Temperature	120	°C	
Lead Temperature	300	°C	
Electrostatic Discharge Protection (1)	4 2	KV kV	HBM CDM

Notes:

- Using Mil Std. 883E, method 3015.7 (human Body Model) and EIA/JESD22C101-A (Charge Device Model)

OPERATING CONDITIONS

PARAMETER	SYMBOL	MIN	TYP	MAX	UNITS	NOTES
Supply Voltage	Vdd	2.7	5.0	6.0	V	
Supply Current	Idd		3 1	4 2	mA uA	Ipo=0mA ENB1=0, ENB2=0
Operating Temp.	To	0		70	°C	Free-air

DC CHARACTERISTICS

PARAMETER	SYMBOL	MIN	TYP	MAX	UNITS	NOTES
Input Voltage	Vi	-0.3		Vdd+0.3	V	
Input Low Voltage	Vil			0.35xVdd	V	ENB1, ENB2
Input High Voltage	Vih	0.65xVdd			V	ENB1, ENB2
Output Voltage	Vpo Vcph Vcpl Vr		(1) (2) 0.6	7.0 8.0 Vdd	V V V V	VPO CP1H, CP2H CP1L, CP2L RB1, RB2
Output Current	Ipo Iled		24	200	mA mA	VPO (3) LED1-4, LED5-8 (4)
Current Matching	Idi	-1		+1	%	LED1-4, LED5-8
Efficiency	Epo	60		90	%	(5)

Notes:

- Vpo (typ) \cong (Vled + 1V), (Vled - LED forward bias voltage).
- Vcph (typ) \cong (Vpo + 0.5V)
- Current sourcing only.
- Current sinking only.
- Epo=(Ipo x Vpo)/(Idd x Vdd), See Fig. 4.

AC CHARACTERISTICS

(Vdd=4.5V, To=0°C to 70°C)

PARAMETER	SYMBOL	MIN	TYP	MAX	UNITS	NOTES
Clock Frequency	Fck	0.9	1	1.1	MHz	CP1H, CP1L, CP2H, CP2L
Pulse Width	Tpw	20		200	nS	ENB1, ENB2 (1)
Settling Time	Ts			10	uS	ENB1, ENB2 (2)
Rise Time	Tr			10	nS	ENB1, ENB2
Fall Time	Tf			10	nS	ENB1, ENB2

Notes:

- Requirement for both High and Low pulses during counter programming.
- Time required for Driver On/Off programming and selected current value to settle.

APPLICATIONS INFORMATION

1) VDD, VPO Capacitor Selection

The style and value of the capacitors used with the BL144 determine several important parameters such as regulator control loop

stability, output ripple, charge pump strength and minimum start-up time.

To reduce noise and ripple, it is recommended that low equivalent series resistance (ESR) ceramic capacitors are used for both VDD and VPO decoupling capacitors. Tantalum and aluminum

capacitors are not recommended due to high ESR. The excessive output capacitor ESR > 100mΩ will tend to degrade the loop stability. Multilayer ceramic chip capacitors typically have exceptional ESR performance and when combined with a tight board layout will result in very good stability. The value of VDD decoupling capacitor controls the amount of ripple present at the VDD input. The BL144's input current will be relatively constant while the charge pump is either in the input charging phase or the output charging phase but will drop to zero during the clock non-overlap times. Since the non-overlap time is small (<40ns), these missing "notches" will result in only a small perturbation on the input power supply line. Note that a higher ESR capacitor such as tantalum will have higher input noise due to the higher ESR. Therefore, ceramic capacitors are recommended for low ESR. Input noise can be further reduced by powering the BL144 through a very small series inductor. A 10nH inductor will reject the fast current notches, thereby presenting a nearly constant current load to the input power supply. For economy, the 10nH inductor can be fabricated on the PC board with about 1cm (0.4") of PC board trace.

2) Pump Capacitor Selection

Warning: Polarized capacitors such as tantalum or aluminum should never be used for the pump capacitors since their voltage can reverse upon start-up of the BL144. Ceramic capacitors should always be used for the pump capacitors.

The pump capacitors control the strength of the charge pump. In order to achieve the rated output current it is necessary to have at least 1μF of capacitance for each of the pump capacitors. Capacitors of different materials lose their capacitance with higher temperature and voltage at different rates. For example, a ceramic capacitor made of X7R material will retain most of its capacitance from -40°C to 85°C whereas a Z5U or Y5V style capacitor will lose considerable capacitance over that range. Capacitors may also have a very poor voltage coefficient causing them to lose 60% or more of their capacitance when the rated voltage is applied. Therefore, when comparing different capacitors, it is often

more appropriate to compare the amount of achievable capacitance for a given case size rather than comparing the specified capacitance value. For example, over rated voltage and temperature conditions, a 1μF, 10V, Y5V ceramic capacitor in a 0603 case may not provide any more capacitance than a 0.22μF, 10V, X7R available in the same case. The capacitor manufacturer's data sheet should be consulted to determine what value of capacitor is needed to ensure minimum capacitances at all temperatures and voltages.

3) Layout Considerations and Noise

Due to the high transient currents produced by the BL144, careful board layout is necessary. A true ground plane and short connections to all capacitors will improve performance and ensure proper regulation under all conditions.

The pump capacitor pins CP1H, CP2H, CP1L and CP2L will have high edge rate waveforms. The large dv/dt on these pins can couple energy capacitively to adjacent PCB runs. Magnetic fields can also be generated if the pump capacitors are not close to the BL144 (i.e., the loop area is large). To decouple capacitive energy transfer, a Faraday shield may be used. This is a grounded PCB trace between the sensitive node and the BL144 pins. For a high quality AC ground, it should be returned to a solid ground plane that extends all the way to the BL144.

The following guidelines should be followed when designing a PCB layout for the BL144:

- The exposed pad should be soldered to a large copper plane that is connected to a solid, low impedance ground plane using plated through-hole vias for proper heat sinking and noise protection.
- Input and output capacitors must be placed close to the part.
- The pump capacitors must be placed close to the part. The traces from the pins to the capacitor pad should be as wide as possible.
- VDD, VPO traces must be wide to minimize inductance and handle high currents.
- LED pads must be large and connected to other layers of metal to ensure proper heat sinking.

Preliminary specification

- RB1 and RB2 pins are sensitive to noise and capacitance. The resistors should be placed near the part with minimum line width.

4) Thermal Management

For higher input voltages and maximum output current, there can be substantial power dissipation in the BL144. If the junction temperature increases above approximately 120°C the thermal shut down circuitry will automatically deactivate the output current sources and charge pump. To reduce maximum junction temperature, a good thermal connection to the PC board is recommended. Connecting the Exposed Pad to a ground plane and maintaining a solid ground plane under the device will reduce the thermal resistance of the package and PC board considerably.

5) Power Efficiency

To calculate the power efficiency (Epo) of a white LED driver chip, the LED power should be compared to the input power. The difference between these two values represents lost power whether it is in the charge pump or the current sources. Stated mathematically, the power efficiency is given by:

$$Epo = P_{out} / P_{in}$$

The efficiency of the BL107 depends upon the mode in which it is operating. Recall that the BL107 operates as a pass switch, connecting VDD to VPO, until dropout is detected at the LED pins. This feature provides the optimum efficiency available for a given input voltage and LED forward voltage.

When it is operating as a switch, the typical efficiency is approximated by:

$$Epo = P_{out} / P_{in} = (I_{po} \times V_{po}) / (I_{dd} \times V_{dd})$$

since the input current will be very close to the sum of the LED currents. At moderate to high output power, the quiescent current is negligible and the expression above is valid. When Vdd has dropped to a level which can not sustain the set LED current, BL107 will enable the charge pump in 2x mode. In 2x boost mode, the efficiency is similar to that of a linear regulator with an effective input voltage of 2 times the actual input voltage. This is because the input current for a 2x charge pump is approximately 2 times the load current. Therefore a typical 2x charge pump without any optimization, the power efficiency would be given by:

$$Epo = P_{out} / P_{in} = (I_{po} \times V_{po}) / (2I_{po} \times V_{dd}) \\ = V_{po} / (2V_{dd})$$

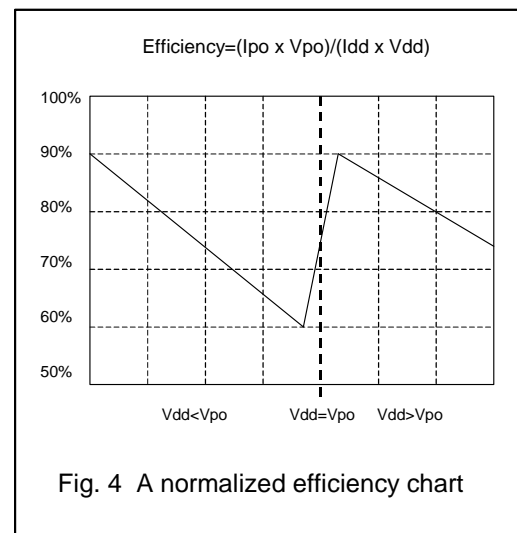

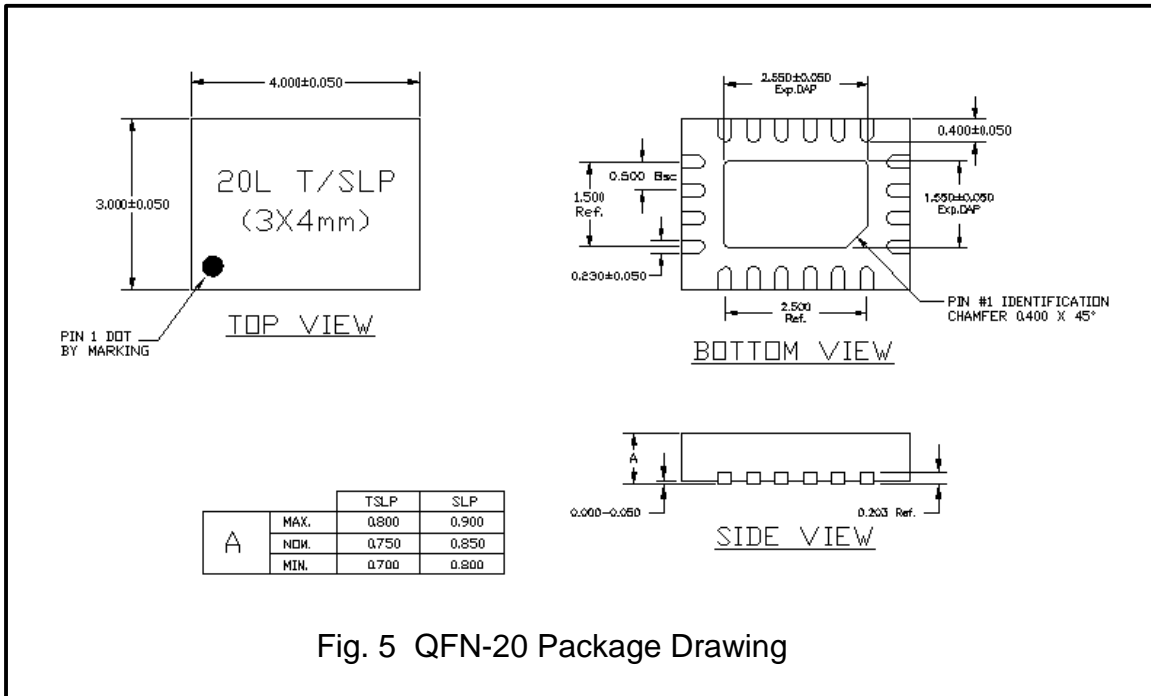

Fig. 5 QFN-20 Package Drawing

Copyright © 2006
 Circuit Integration Technology, Inc.
 Phone: (650) 968-5950 Fax: (650) 968-5952
 Web: www.cittek.com

Information furnished here are believed to be accurate and reliable. However, no responsibility is assumed for its use. CIT reserves the right to change the circuitry and specifications without notice at any time. No circuit patent licenses are implied.