

10-bit Bus Switch

FEATURES

- Enable Signal is SSTL_2 Compatible.
- Optimized for Use in DDR SDRAM Applications.
- Flow-through Architecture Optimizes PCB Layout.
- Designed to be Used With 200Mbps.
- Switch on Resistance is Designed to Eliminate the Need for Series Resistor to DDR SDRAM.
- Internal 10-KΩ Pull-down on Output Enable Input.
- Full DDR Solution Provided When Used With CB857 and STL16857.

PIN ASSIGNMENT

24-Pin TSSOP Package

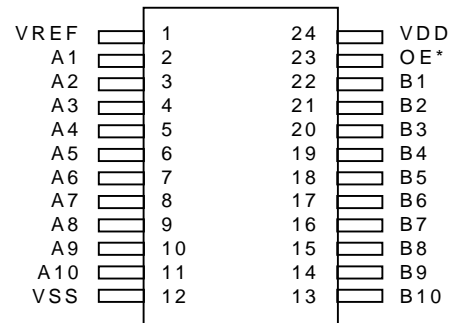

DESCRIPTION

This 10-bit FET bus switch is designed for 3V to 3.6V V_{dd} operation and SSTL_2 output enable (OE*) input levels. When OE* is LOW, the 10-bit bus switch is on and port A is connected to port B. When OE* is HIGH, the switch is open, and a high-impedance state exists between the two ports. The low on-state resistance of the switch allows connections to be made with minimal propagation delay. The BS3857 is characterized for operation from 0°C to 85°C.

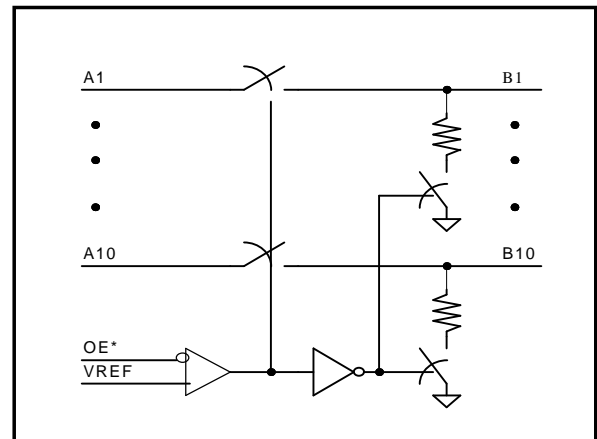

FIG. 1. FUNCTIONAL BLOCK DIAGRAM

PIN DESCRIPTION

PIN	SYMBOL	DESCRIPTION
1	VREF	Vref input
2, 3, 4, 5, 6, 7, 8, 9, 10, 11	A1-A10	Port Inputs
12	VSS	Ground
22, 21, 20, 19, 18, 17, 16, 15, 14, 13	B1-B10	Port Outputs, 10KΩ termination when Off.
23	OE*	Output Enable, Switch is on when Low
24	VDD	Positive supply voltage

FUNCTION TABLE

OE*	Mode
L	Port A = Port B
H	Port A high impedance Port B 10KΩ pull-down

Notes:
H= Logic High, L= Logic Low

RECOMMENDED OPERATING CONDITIONS

PARAMETER	SYMBOL	MIN	TYP	MAX	UNITS	NOTES
Supply Voltage	Vdd	3.0	3.3	3.6	V	
Reference Voltage	Vref	1.15	1.25	1.35		Vref = 0.38xVdd
Operating Temperature	To	0		70	°C	

DC CHARACTERISTICS

PARAMETER	SYMBOL	MIN	TYP	MAX	UNITS	NOTES
Quiescent Current	Idd			1	mA	
Input Voltage Low	Vil	-0.5		Vref-0.18	V	OE*
Input Voltage High	Vih	Vref+0.18		Vddq+0.5	V	OE*
Input Current	Ii			±5	uA	Any input
On Resistance	Ron	20		30	Ω	Port A to B
Off Resistance	Roff	1			MΩ	Port A

AC CHARACTERISTICS

(Cl=30pF; 0°C to 70°C)

PARAMETER	SYMBOL	MIN	TYP	MAX	UNITS	NOTES
Propagation Delay	Tp			750	pS	Port A to B Port B to A OE* to Port A & B
		1		3		
Input Capacitance	Cin	2		4	pF	Port A or B

Copyright © 1999
Circuit Integration Technology, Inc.
Phone: (40*) 747-0206 Fax: (408) 747-0269

Information furnished here are believed to be accurate and reliable. However, no responsibility is assumed for its use. CIT reserves the right to change the circuitry and specifications without notice at any time. No circuit patent licenses are implied.