

Multi-Mode SCSI Terminator

FEATURES

- Fully Compliant With Ultra2, Ultra3 and Ultra320 SCSI Standards.
- Build In Low Pass Filter On DIFF_IN Pin.
- Low Terminal Capacitance of 2pF
- Fast Response Regulator, No External Capacitors Required.
- Auto-selection of LVD or SE Mode
- Provides Multi-mode Termination for 9 Signal Line Pairs
- Differential Fail-safe Bias.
- Low Power with On Demand Consumption Only.
- SCSI Bus Hot Plug Compatible
- Fully Supports Actively Negated SE SCSI Signals

PIN ASSIGNMENT

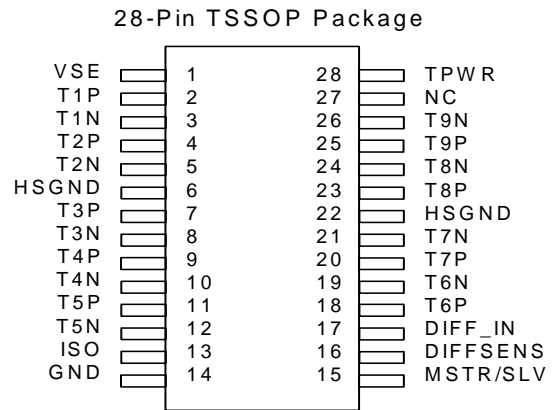

DESCRIPTION

The ST18-28 multi-mode SCSI Terminator is both a Low Voltage Differential (LVD) and Single-Ended (SE) terminator for the transition to the next generation SCSI bus interface. If the device is connected in an LVD only bus, the ST18-28 will use LVD termination. If any SE devices are connected to the bus, the ST18-28 will use SE termination. Automatic mode selection is achieved through voltage detection on the DIFFSENSE line. For the LVD termination, the ST18-28 integrates two regulated supplies with nine precision resistor strings. For the SE termination, one regulator and nine precision 110 ohm resistors are used. The ST18-28 cannot be used with SCSI differential EIA485. ST18-28 will shutdown when it sees high voltage on the line in order to protect the device.

The external capacitors may be eliminated with the fast response voltage regulator design on VSE pin and the build in low-pass filter on DIFF_IN pin.

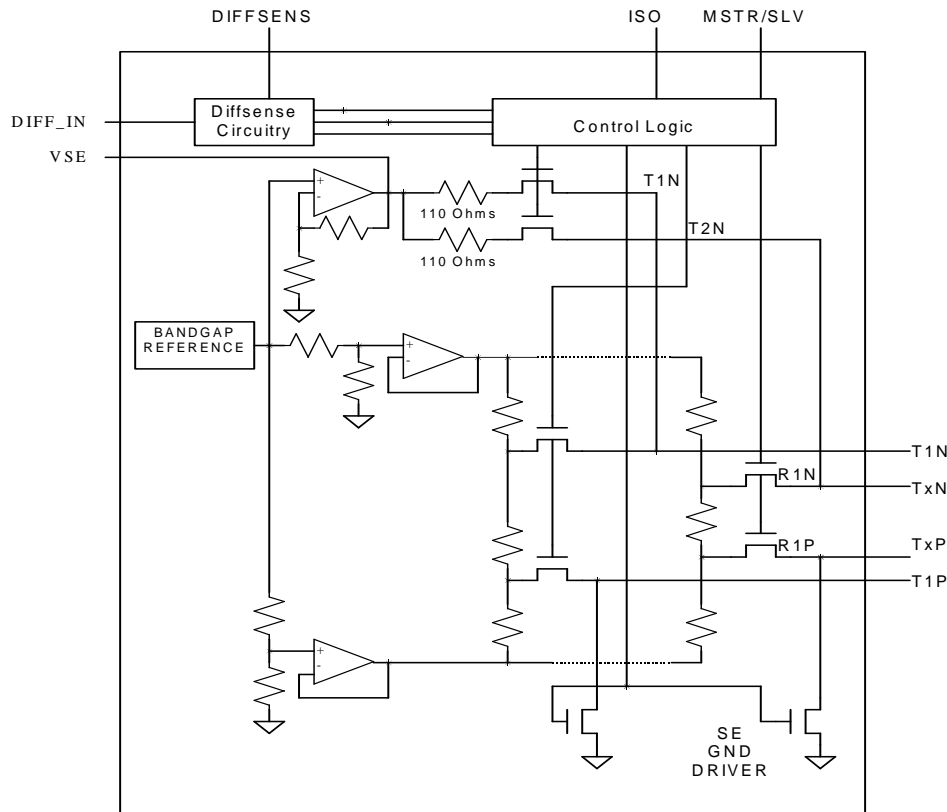

FIG. 1. FUNCTIONAL BLOCK DIAGRAM

PIN DESCRIPTION

PIN	SYMBOL	DESCRIPTION
1	VSE	2.8V Source It is disabled to Low when not in SE mode. May be used as SE mode indicator. An optional 4.7uF capacitor may be used for signal filtering. Should the 4.7uF is not used a 0.01uF capacitor is recommended for high frequency noise decoupling.
2-5, 7-12, 18-21, 23-26	TxP TxN	Signal Termination. Connect to SCSI bus signal lines. TxP are positive lines for differential mode and ground lines for single ended mode. TxN are negative lines for differential mode and signal lines for single ended mode.
6, 22	HSGND	Heat Sink Ground. Internally connected to the mounting pad. Connect to large area PC board traces to increase power dissipation capability.
13	ISO	Isolation. When pulled high, the ST18-28 isolates its bus pins (TxP, TxN) from the SCSI bus. Internal 100KΩ resistor to ground.
14	GND	Ground. Signal ground.
15	MSTR/SLV	Master/slave. TTL level input, Logic High enables the DIFFSENS driver.
16	DIFFSENS	DiffSense Output. Output to drive the SCSI bus DIFFSENS line.
17	DIFF_IN	DiffSense Input. Input for mode detection (differential, single-ended, or high voltage) on the SCSI bus. Build in low-pass filter to remove high frequency transients. An optional 20KΩ resistor and a 0.1μF capacitor may be used externally.
27	NC	No Connection. Do not connect this pin.
28	TPWR	Terminator Power. Connect to SCSI bus TERMPWR line and decouple with 2.2 μF capacitor plus a 0.01uF high frequency capacitor recommended.

FUNCTIONAL DESCRIPTION

DIFFSENSE

The DIFFSENS section consists of a 1.3V, 5mA driver and a sensing circuit (Figure 1). The DIFFSENS pin drives the SCSI DIFFSENS bus line. The DIFF_IN pin monitors the DIFF-SENS line voltage to determine the proper operating mode of the device.

Port Isolation

ST18-28 isolates the termination ports from the bus and both DIFFSENS driver and VSE regulator are shut down when ISO = 1, or high voltage is detected on the bus. During thermal shut-down, the termination ports are isolated from the SCSI bus, DIFFSENS driver is shut down and VSE becomes high impedance. To ensure proper operation, the TPWR pin should be connected to the SCSI bus TERMPWR line.

Layout Recommendations

The TERMPWR and VDD lines should be bypassed locally. A 2.2uF capacitor and a

0.01uF high frequency capacitor is recommended between TPWR and ground and placed as close as possible to the ST18-28. A larger value capacitor may be used for TPWR if the power line is extra unstable during hot swap. The capacitors for VSE and DIFFSENS signal filtering and the 20K resistor on DIFFSENS line are optional. Should the 4.7uF capacitor is not use on VSE pin a 0.01uF capacitor is recommended for high frequency decoupling. The ST18-28 should be placed as close as possible to the SCSI connector to minimize signal and power trace length. The traces on PC board are recommended to be about 110Ω in impedance. In differential mode the P and N pair are best be running in parallel to minimize common mode noises. The placement of the devices should be in such a manner that the line length extremes are avoided. A typical SCSI bus configuration is shown in Figure 2.

ABSOLUTE MAXIMUM RATINGS

Termpower Voltage	7V
Signal Line Voltage	0V to Vtpwr
Package Power Dissipation (TSSOP 28)	1W
Storage Temperature	-65°C to 150°C
Junction Temperature	-55°C to 150°C
Lead Temperature (Soldering, 10 sec.)	300°C

RECOMMENDED OPERATING CONDITIONS

PARAMETER	SYMBOL	MIN	TYP	MAX	UNITS	NOTES
Termpower Voltage	Vtpwr	4.0		5.50	V	
Logic 0	Vil	-0.3		+0.8	V	
Logic 1	Vih	2.0		Vtpwr+0.3	V	
Operating Temperature	To	0		70	°C	

SINGLE ENDED CHARACTERISTICS

PARAMETER	SYMBOL	MIN	TYP	MAX	UNITS	NOTES
SE Terminator Resistance	Rse	102.3	110	117.7	Ohms	Vline=0.2volts
SE Voltage	Vse	2.6	2.8		Volts	
SE Output Current	Iose			25.4	mA	Vline=0.2volts
Terminal Capacitance	Cte			3	pF	guaranteed by design

LOW VOLTAGE DIFFERENTIAL CHARACTERISTICS

PARAMETER	SYMBOL	MIN	TYP	MAX	UNITS	NOTES
Differential Mode	Rdm	100		110	Ohms	Vd=±1.0V

Termination Resistance						
Common Mode Termination Resistance	Rcm	100		200	Ohms	
Differential Mode Bias	Vdm	100		125	mV	All lines open
Common Mode Bias	Vcm		1.25		V	

DC CHARACTERISTICS

PARAMETER	SYMBOL	MIN	TYP	MAX	UNITS	NOTES
Termpower Current	Itpmr		20 600		mA μA	All lines open ISO=1
Input Leakage High	Iih	-1.0			μA	
Input Leakage Low	Iil			1.0	μA	
DIFFSENS SE Voltage Range	Vseor	-0.3		0.5	V	
DIFFSENS LVD Voltage Range	Vlvdor	0.7		1.9	V	
DIFFSENS HVD Voltage Range	Vhv dor	2.4		Vtpm+ 0.3	V	
DIFFSENS Driver Output Voltage	Vdso	1.2		1.4	V	MSTR/SLV=1; Vds=0.5mA
DIFFSENS Driver Source Current	Idsh		5	15	mA	MSTR/SLV=1, Vdso=0V
DIFFSENS Driver Sink Current	Idsl	20		200	μA	MSTR/SLV=1; Vdso=2.75V

REGULATOR CHARACTERISTICS

(0°C to 70°C)

PARAMETER	SYMBOL	MIN	TYP	MAX	UNITS	NOTES
Line Regulation	RLld		1.0	2.0	%	
Load Regulation	RLln		1.3	3.0	%	
Current Limit	Ilim		350		mA	
Sink Current	Isink	200			mA	

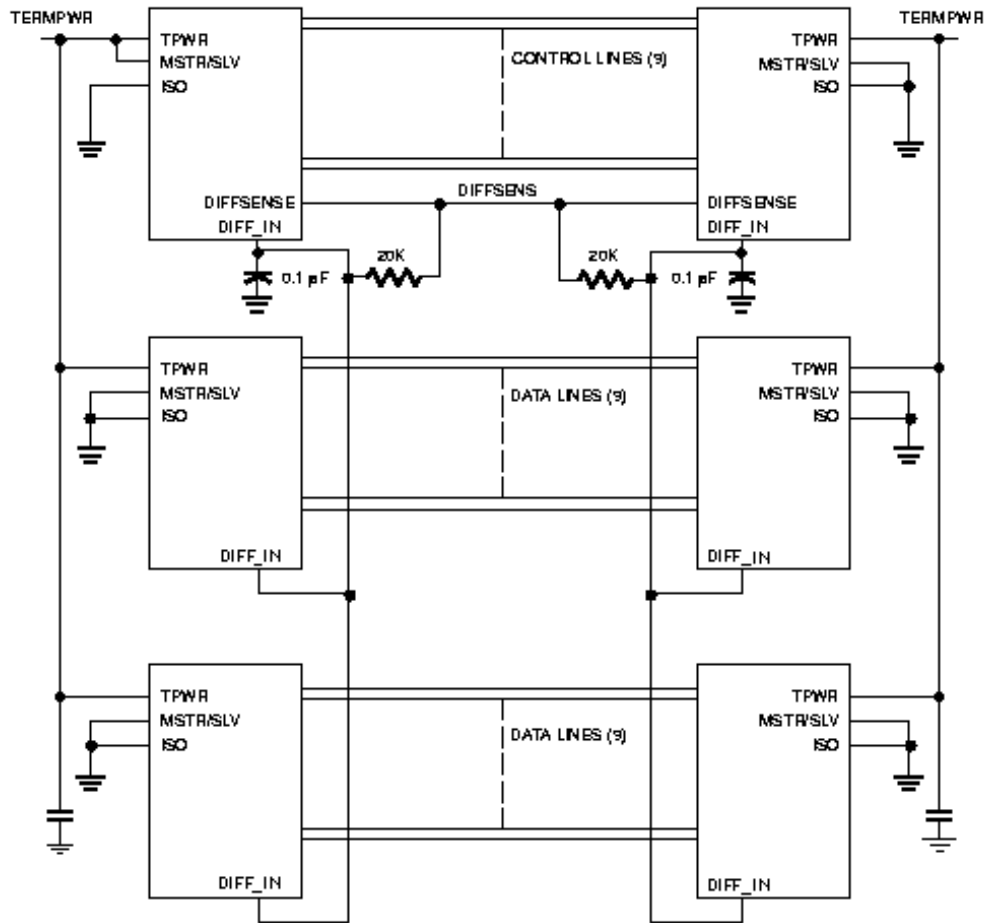
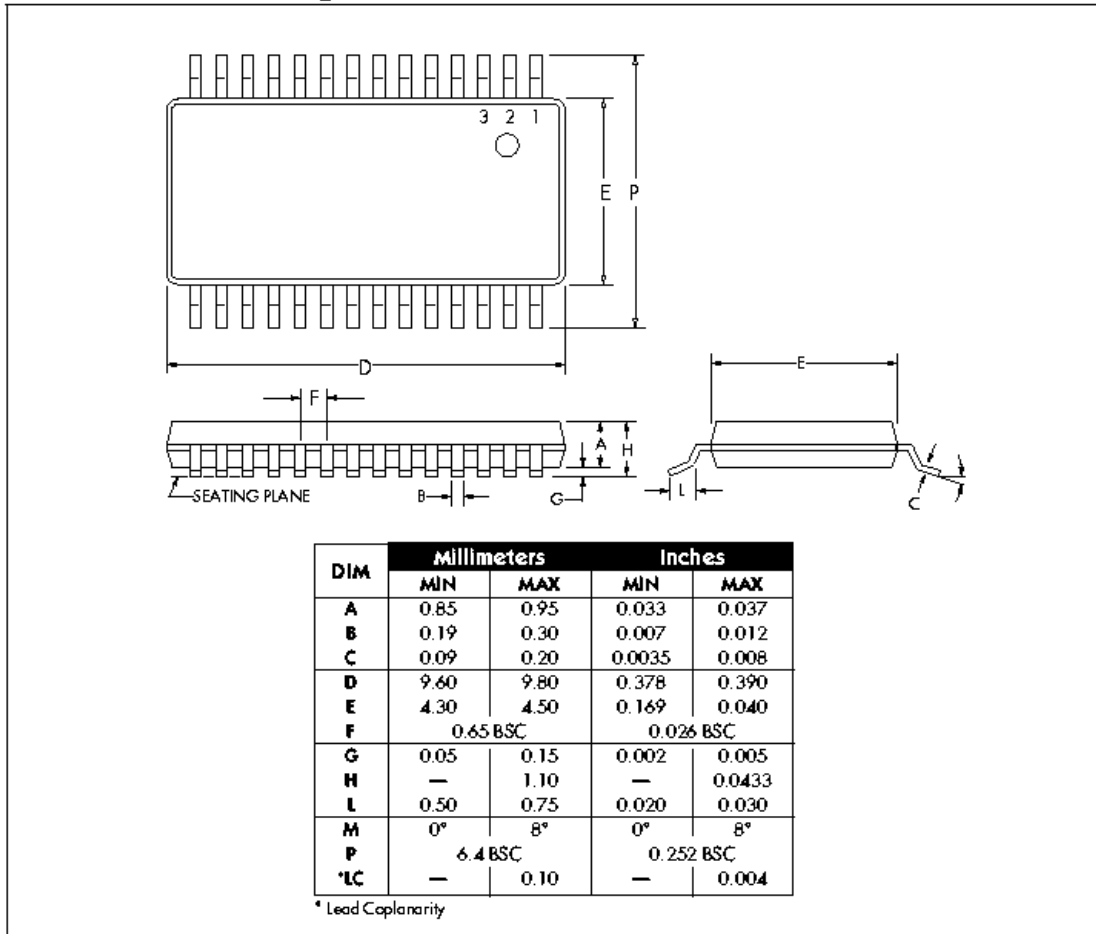

FIG. 2. SCSI BLOCK DIAGRAM

TSSOP 28 Package Dimension



Copyright © 2003
 Circuit Integration Technology, Inc.
 Phone: (650) 968-5950 Fax: (650) 968-5952
 Web: www.cittek.com

Information furnished here are believed to be accurate and reliable. However, no responsibility is assumed for its use. CIT reserves the right to change the circuitry and specifications without notice at any time. No circuit patent licenses are implied.